

Yamaha electric feeder wiring

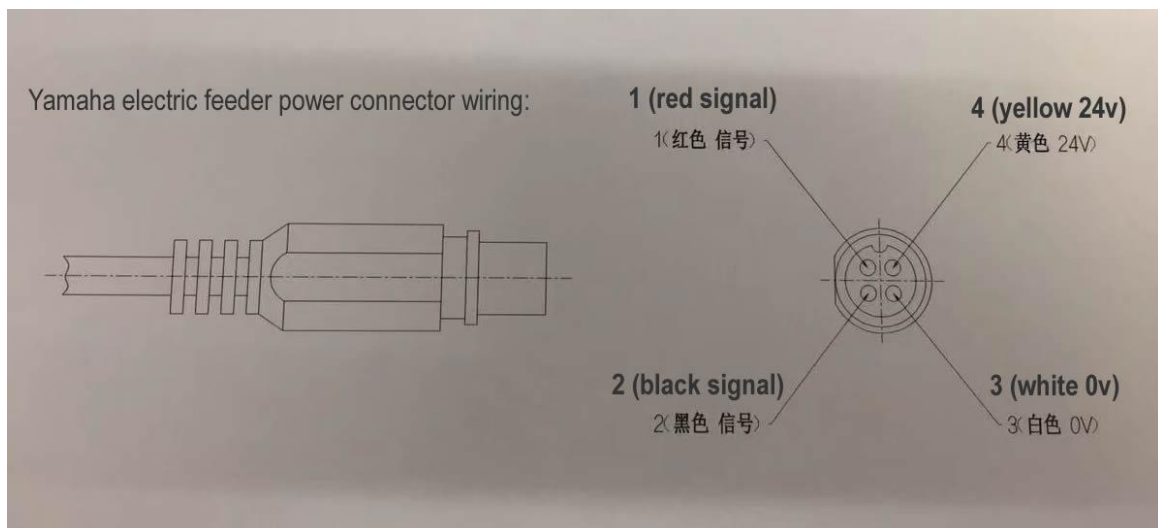

If there is no airflow compact from your current pick and place machine, here is the wire details:

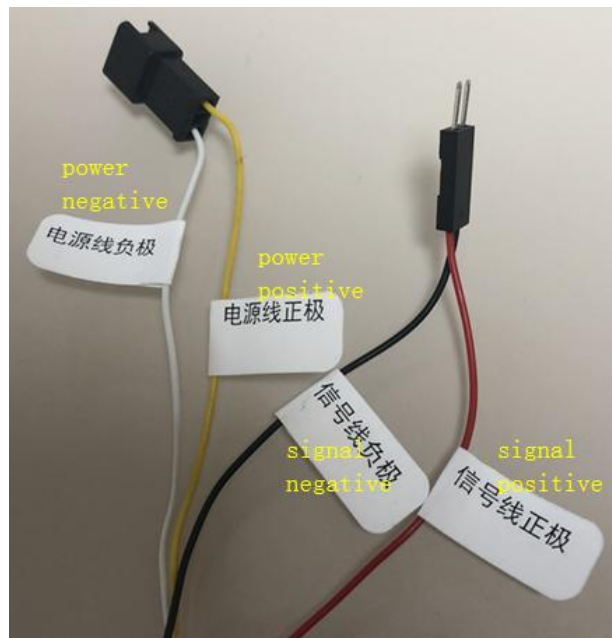

Yamaha electric feeder

How to install material tape

ST 8-12MM

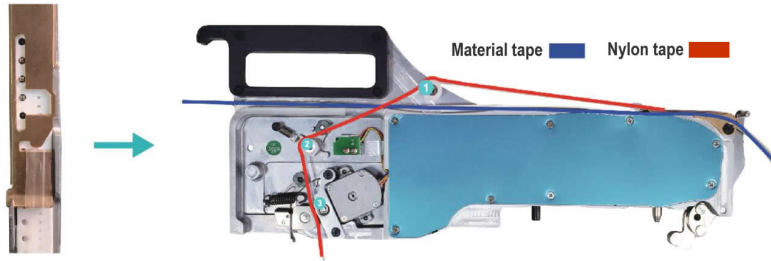

1. The tape passes through the material pressing cover, aligning the holes of the tape with the gears, and the material film emerges from above the material pressing cover.

2. After the material film emerges from the material pressing cover, it sequentially passes through positions 1, 2, and 3. Once completed, the feeder can be installed on machine.

ST 12/16MM

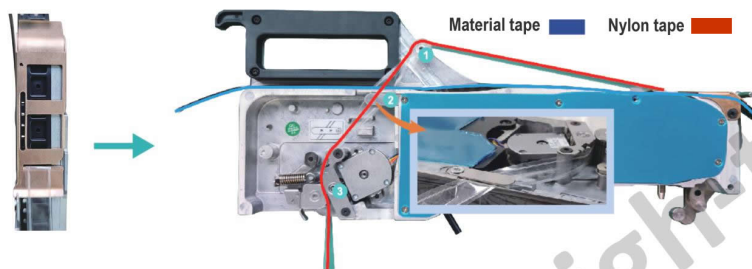

1. The tape first passes through the material pressing cover, aligning the holes of the tape with the gears, and the material film emerges from above the material pressing cover.

2. After the material film emerges from the material pressing cover, it sequentially passes through positions 1, 2, and 3. When passing through position 2, the material film must pass through the inside of the stopper. Once completed, the feeder can be installed on machine.

STS 12-44MM

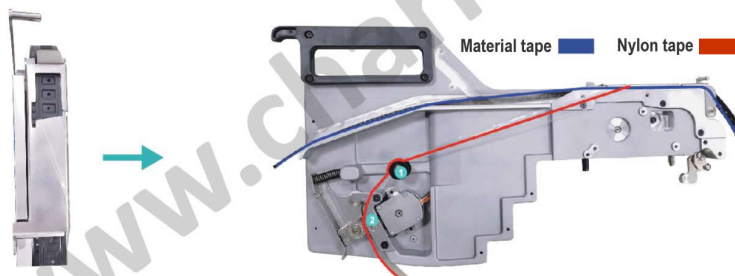

1. The tape passes through the material pressing cover first, aligning the holes of the tape with the gears, and the material film emerges from above the material pressing cover.

2. After the material film emerges from the material pressing cover, it sequentially passes through positions 1 and 2. Once completed, the feeder can be installed on machine.

Hook tightness adjustment ST/STS

Key Description

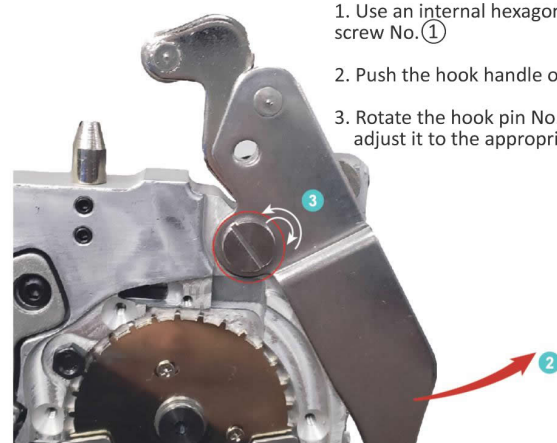
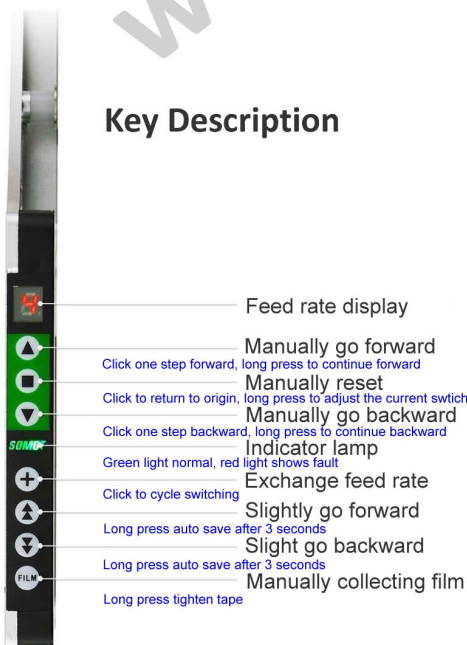

1. Use an internal hexagonal loosening half-turn screw No. ①
2. Push the hook handle outward to tighten No. ②
3. Rotate the hook pin No. ③ left and right, adjust it to the appropriate position.

Slightly Adjust Function

Double click Reset  → Nozzle positioning → long press  for 3 seconds auto save → click  Forward to check the position

Note: Generally, adjust the forward fine-tuning first. After adjusting the backward fine-tuning to the ideal position, the feeder has an automatic reset function. At this time, you still need to press the forward fine-tuning button to make the motor gears engage tightly without any gap. At this point, the discharging position after the forward fine-tuning is the most standard.

ST Feeder Electric/ Air Signal Switching

Click Reset  → long press pitch switching button  for 5 seconds → click forward button  choose "d" or "f" (d means electric, f means air) → long press film  for 5 seconds auto restart and save





Note: The 8mm feeder will display the initial step distance "4" or "2", and the 12/16/24mm.. feeder will display numbers such as 1/2/3/4.

Material Feeding Speed Adjustment

Click Reset  → long press pitch switching button  for 5 seconds → click backward button  choose the feeding speed → long press film  for 5 seconds auto restart and save

Note: Default medium speed is set at level 3. Continuing to press the downward arrow will cycle through levels 4, 5, 6, 1, 2, 3. Level 6 is the fastest, while level 1 is the slowest. When the speed is set to level 6, the corresponding motor strength should be adjusted to the "□" level.

Motor strength adjustment

Click Reset  → long press Reset  button for 5 seconds → click forward button  choose strength level → long press film  for 5 seconds auto restart and save





Note: Default is second gear. Continuing to press the forward button cycles through third gear, fourth gear, first gear, and second gear. Fourth gear has the maximum strength, while first gear has the minimum strength.

Intelligent correction system (8mm feeder only)

Click Reset  → long press pitch switching button  for 5 seconds → Click Reset  choose “u” or “n” → long press film  for 5 seconds auto restart and save

Note: “u” means turn on intelligent correction system, “n” means turn off intelligent correction system.

Reset to factory set(8mm feeder only)

Click Reset  → long press Reset  button for 5 seconds → click backward button  choose number “0” → long press film  for 5 seconds auto restart and save

Common troubleshooting methods

Red Light Alarm:

If the alarm occurs irregularly or for a dozen components, return it to us directly. If the alarm occurs for one or two components, open the back cover directly and check if the gears can rotate smoothly. The stuck part is the problem area, clear it. (Figure1)

No Tape Feeding:

(No Tape Peeling Phenomenon) Separate the two engaging gears of the rear tape peeler and try to move them smoothly by hand. If they are not smooth, check if there is tape peeling or thread wrapped around the two engaging gears. Clean if necessary; another situation is to check if there are any materials stuck in the small copper teeth under the small front cover.(Figure2)

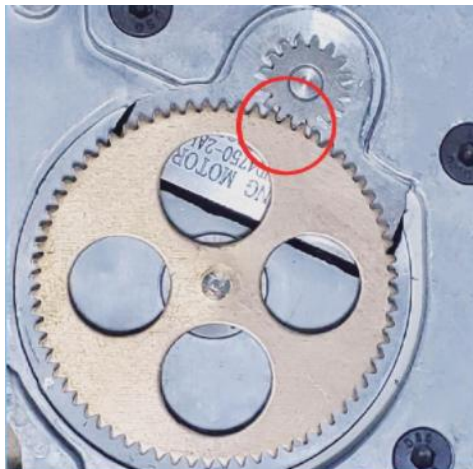

(Figure1)

CHARMHIGH TECHNOLOGY LIMITED
E-mail: kimi@charmhigh-tech.com
Skype: kimiliu89
WhatsApp: +86 135 1067 5756



(Figure2)